

Parts List

Tools needed:

- JigSaw
- Drill
- Drill bit size 1/8"
- Phillips Screw Driver
- Pencil

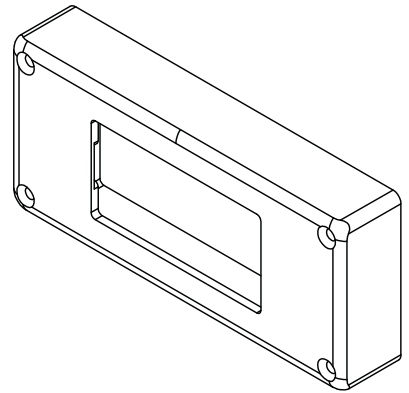

Outlet Faceplate

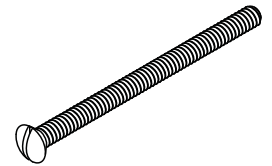
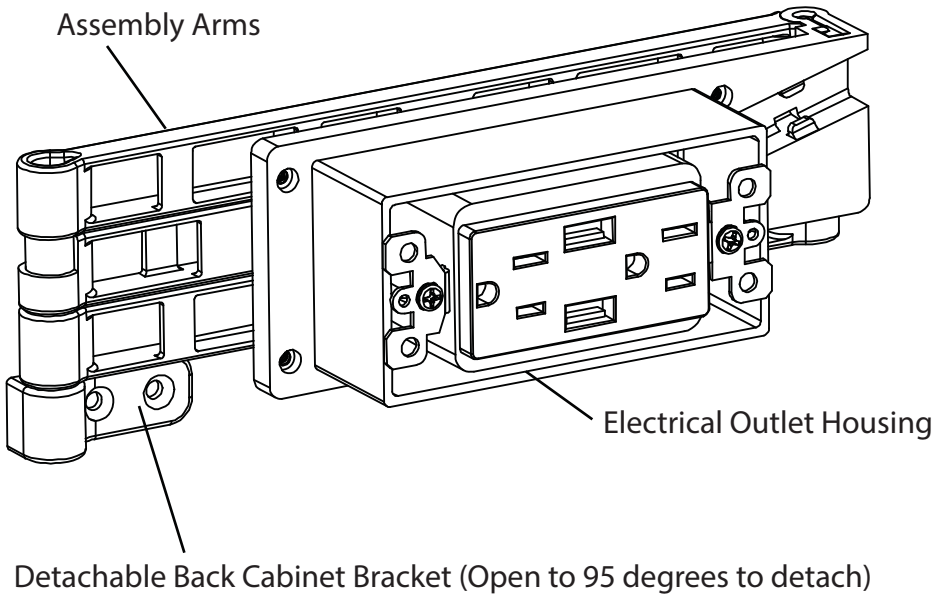

4 Machine Screws



2 Wood Screws

Drawer Box Cutout Template

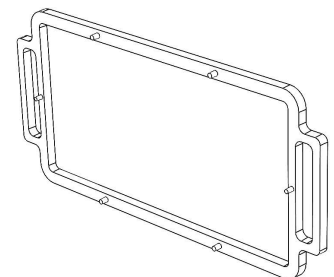
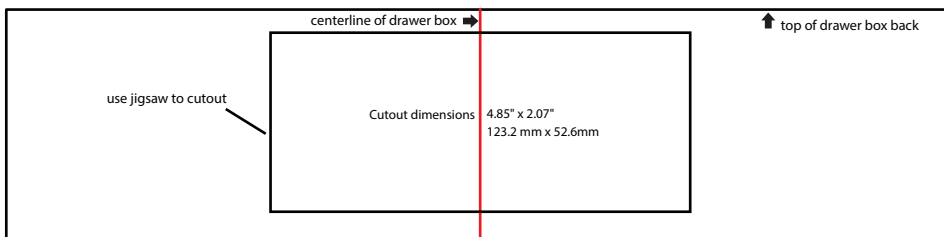

Spacer for 1/2" drawer box.

Back Cabinet Bracket Attachment Template

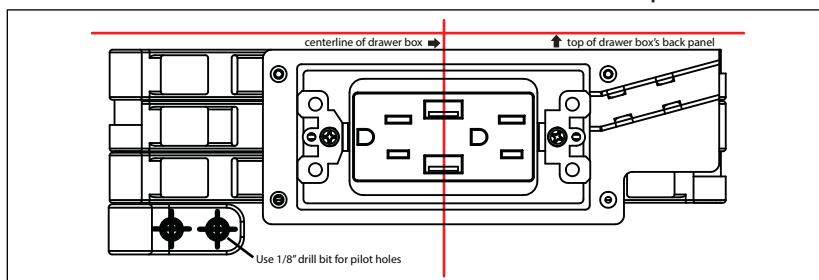

WARNING: Do not plug Compact Drawer Outlet assembly into power source until all installation steps have been completed.

Lista de Partes - Espanol Les Pièces - Français

Herramientas necesarias:

- Sierra caladora
- Taladro
- 3mm broca
- Destornillador de estrella
- Lápiz

Outils nécessaires:

- Scie sauteuse
- Perceuse
- 3mm perceuse mèche
- Tournevis cruciforme
- Crayon

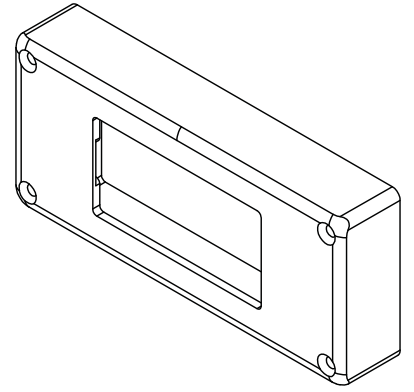

Placa Frontal de la salida eléctrica
Plaque Frontale de la prise de courant

Brazos de Ensamblado
Bras d'Assemblage

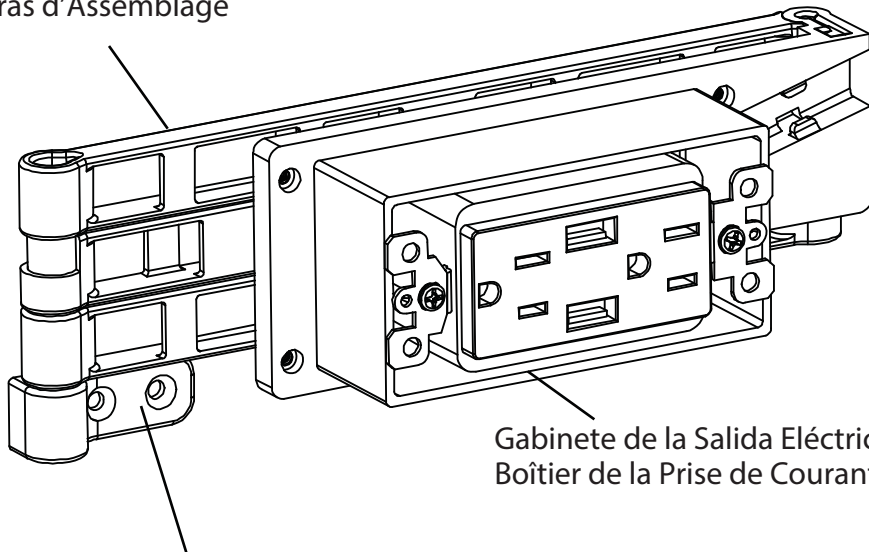

Gabinete de la Salida Eléctrica
Boîtier de la Prise de Courant

Soporte Desmontable del Gabinete Trasero (abierto a 95 grados para separarlo)
Support de Dos d'Armoire Amovible (ouvrir à 95° pour le retirer)

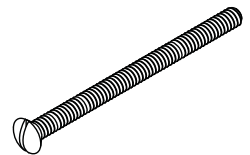

4 Tornillos de la Máquina
Vis à Métaux



2 Tornillos para Madera
Vis à Bois

Plantilla de Recorte de la caja del cajón
Gabarit de Découpe du boîtier de tiroir

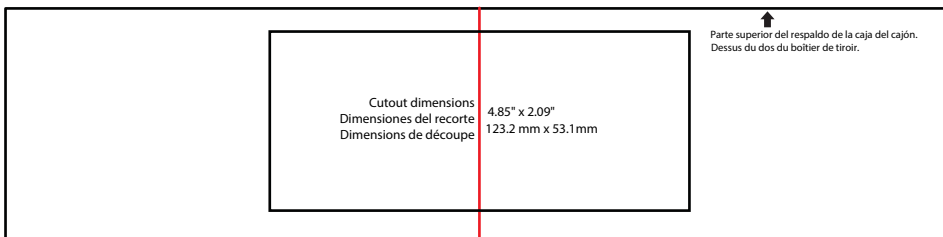

Plantilla de Fijación del soporte del gabinete trasero
Gabarit de Fixation du support de dos d'armoire

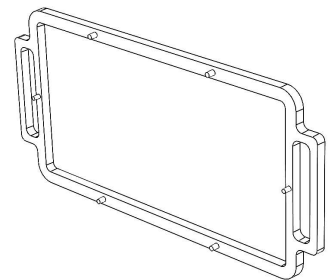
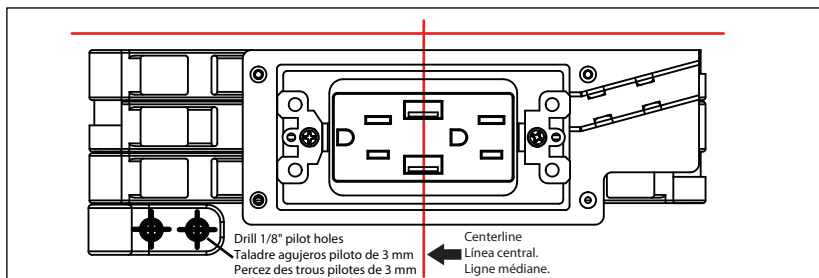

Espaciador para 12.7mm caja del cajón.
Entretoise pour 12.7mm boîtier de tiroir.

ADVERTENCIA: No enchufe el conjunto a una fuente de alimentación sino hasta que se hayan concluido todos los pasos de la instalación.

AVERTISSEMENT: Ne pas brancher l'assemblage dans la source d'alimentation avant que toutes les étapes de l'installation aient été accomplies

